

# NSS SERIES SEWAGE PUMP

## APPLICATIONS

Designed and built for commercial sewage and effluent application.

## FEATURES

- Powerful High Torque / Continuous Rated Duty Motor
- Heavy Duty Cast Iron Impeller (Vortex Design)
- Double Mechanical Seal
- Non Clog Design (2" Free Passage)

## SPECIFICATIONS

MODEL	NSS2-6.4S	NSS2-6.75S
Motor (Hp)	1/2	1
Voltage (V)	115	115
Phase	Single	Single
Hertz (Hz)	60	60
RPM	3450	3450
Full Load Amp @115V	9	14
Discharge Connection FNPT	2"	2"
Solid Passage	2"	2"
Std. Cable Length (Ft)	32	32
Shipping Weight (Lbs)	34.2	40.1

## PERFORMANCE

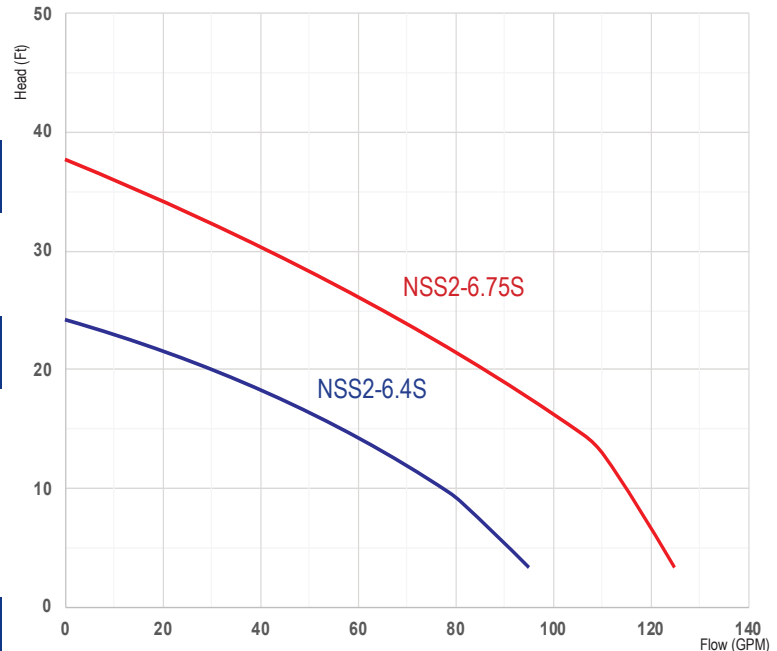

## DIMENSIONS

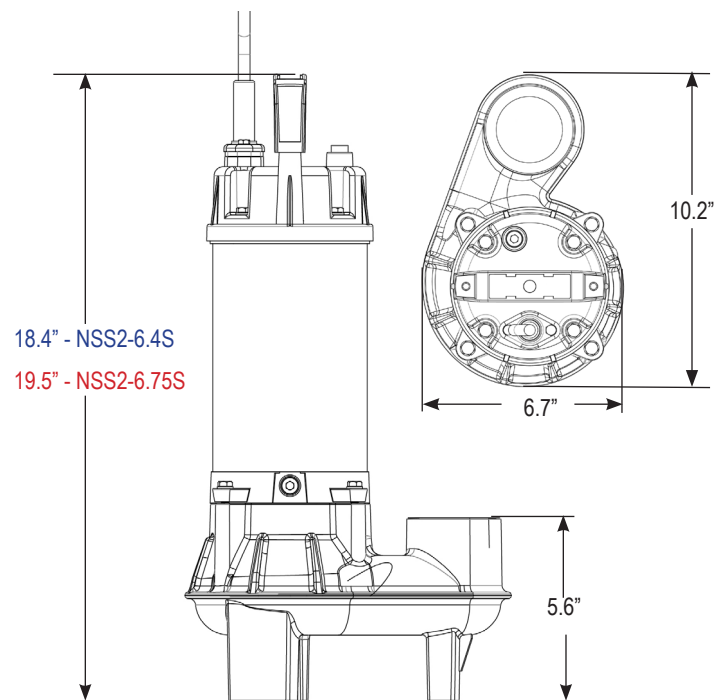

TNSS-2021-02