

NDT SERIES DEWATERING PUMP

PERFORMANCE

APPLICATIONS

Designed and built for the rigors of industrial and commercial dewatering applications. Engineered High Wear Resistance parts for efficient and long lasting reliable performance.

FEATURES

- Powerful High Torque / Continuous Rated Duty Motor
- High Efficiency / Heavy Duty Cast Iron Impeller
- Built in Thermal Protector
- Double Mechanical Seal

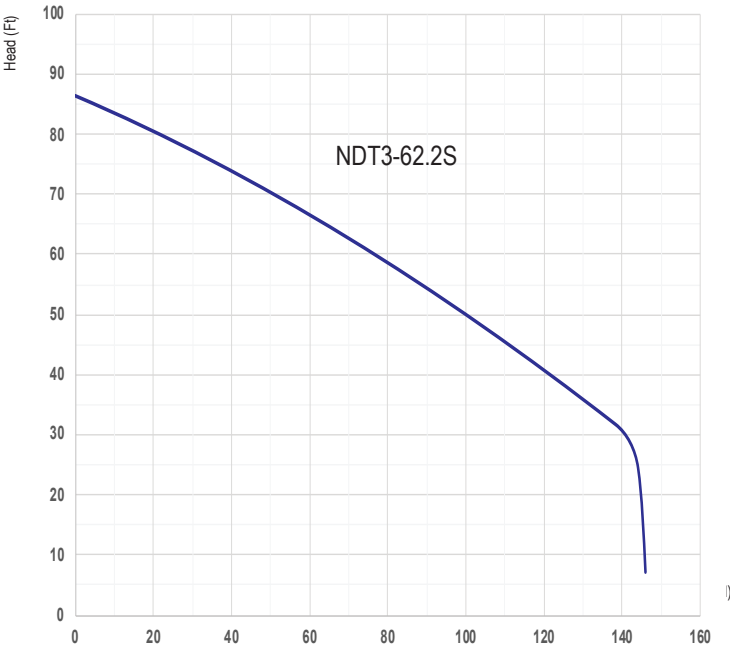

SPECIFICATIONS

| MODEL | NDT3-62.2S |
|------------------------|------------|
| Motor (Hp) | 3 |
| Voltage (V) | 230 |
| Phase | Single |
| Hertz (Hz) | 60 |
| RPM | 3450 |
| Full Load Amp @ 230V | 14 |
| Discharge Connection | 3" |
| Solid Passage | 0.4" |
| Std. Cable Length (Ft) | 32 |
| Shipping Weight (Lbs) | 121 |

DIMENSIONS

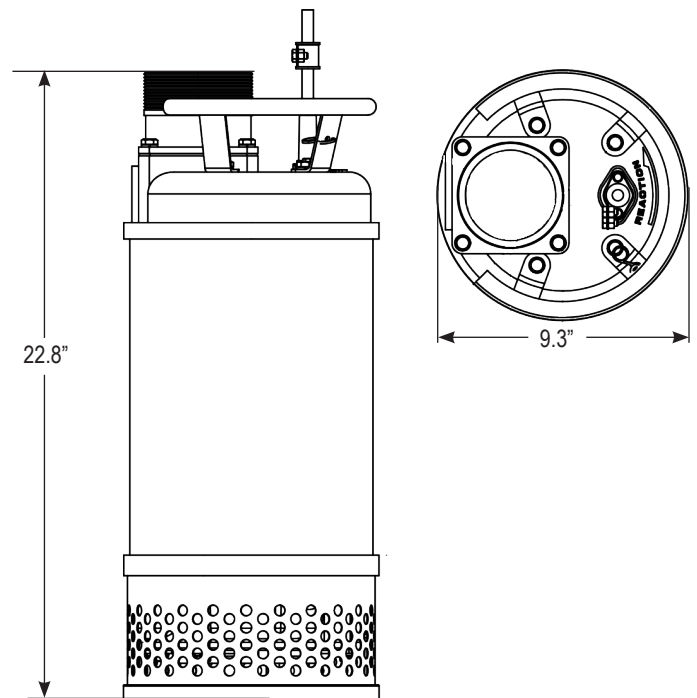

TNSS-2021-03