

DIMENSIONAL DRAWING  
MONOSTAGE CENTRIFUGAL PUMP  
TRAVAINI PUMP MODEL

TCD 100

FLANGES ARE DRILLED  
TO ANSI B16.5 (CLASS 150)

BARESHAF CONSTRUCTION

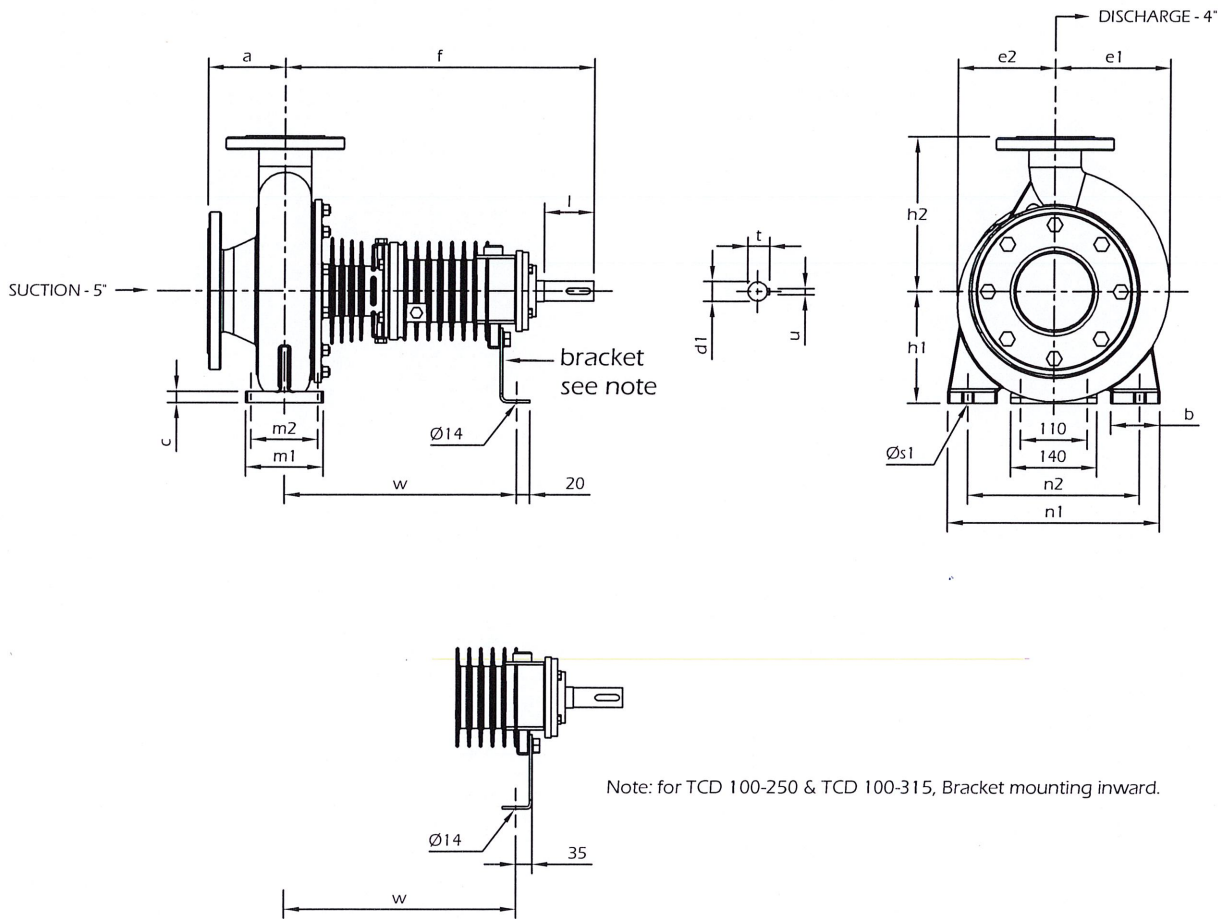

MODEL	f	h1	h2	a	b	c	m1	m2	n1	n2	s1	w	d1	l	t	u	e1	e2	WEIGHT (Kg)
TCD 100-200	500	200	280	125					360	280			32	80	35	10	211	170	78
TCD 100-250	530	225		140	80	20	160	120	400	315	18	370	42	85	45	12	215	183	110
TCD 100-315		250	315														250	225	132



**Premier Fluid Systems**  
Canadian Home of Travaini Pumps

4161 Morris Dr. Unit 5 • Burlington • Ontario • L7L 5L5 • Website: [www.pfspumps.com](http://www.pfspumps.com)  
Tel: 1-800-461-2611 or 905-637-2611 • Fax: 905-333-4722 • e-mail: [info@pfspumps.com](mailto:info@pfspumps.com)

DATE : JULY 2020

No.: 15.58

**TCD 100**

**BASE-MOUNTED CONSTRUCTION**

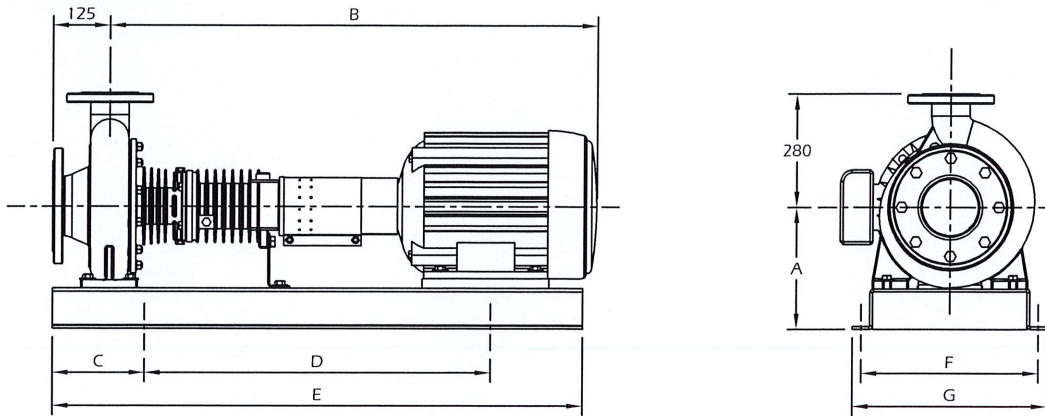

MODEL	MOTOR	HP	A	B	C	D	E	F	G	BASE	*WEIGHT (Kg)
TCD 100-200	213T	7½	302	984	152	889	1193	470	508	907	222
	215T	10		1022							231
	254T	15		1080							263
	256T	20	1127	286							
	364TS	60	1321	572							
	365TS	75	1353	617							
405TS	100	1410	689								
			381		305	1041	1651	711	762	C13**	

MODEL	MOTOR	HP	A	B	C	D	E	F	G	BASE	*WEIGHT (Kg)
TCD 100-250	254T	15	327	1094	152	889	1193	470	508	907	321
	256T	20		1138							341
	284T	25	368	1160	203	940	1346	476	508	C11**	372
	286T	30		1198							395
	405TS	100	394	1445	305	1041	1651	622	652	C13**	691
	444TS	125		1524							783
	445TS	150		1574							895

MODEL	MOTOR	HP	A	B	C	D	E	F	G	BASE	*WEIGHT (Kg)
TCD 100-315	256T	20	352	1130	152	889	1193	470	508	907	360
	284T	25		1156							394
	286T	30	361	1194	203	940	1346	476	508	C11**	417
	324T	40		1222							471
	326T	50		1260							498

\* Weights - Pump, Motor & Base.  
 \*\* With drip tray under pump.

Dimensions in mm



**Premier Fluid Systems**  
 Canadian Home of Travaini Pumps

4161 Morris Dr. Unit 5 • Burlington • Ontario • L7L 5L5 • Website: www.pfspumps.com  
 Tel: 1-800-461-2611 or 905-637-2611 • Fax: 905-333-4722 • e-mail: info@pfspumps.com

DATE : JULY 2020

No.: 15.58.1