

HYDROSYS FULL RECOVERY VACUUM SYSTEM

ITEM NO.	QTY.	DESCRIPTION
1	1	Vacuum Pump/Motor Assembly
1	1	Travaini Vacuum Pump
2	1	Coupling Flange
1	1	Coupling Insert
1	1	Lantern
1	1	Adapter Flange
1	1	Motor 1800RPM 3/60 TEFC C-Flange
2	1	Structural Frame
3	1	Separator/Reservoir Tank
4	2	Temperature Gauge (0-250 F)
5	1	Compound Gauge
6	1	Circulation Pump (Optional)
7	1	Motor 1800RPM 3/60 TEFC (Optional)
8	2	Isolating Ball Valve
9	1	Heat Exchanger
10	1	Y-Strainer
11	1	Isolation Ball Valve
12	1	Level Gauge
13	1	Make-Up Inlet Float Valve
14	1	Vacuum Gauge (0-30" Hg)
15	1	Inlet Check Valve

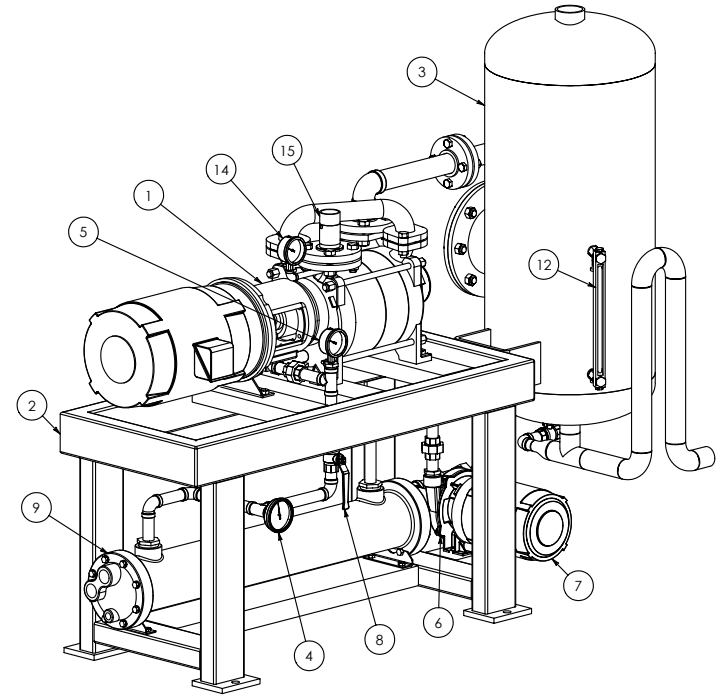
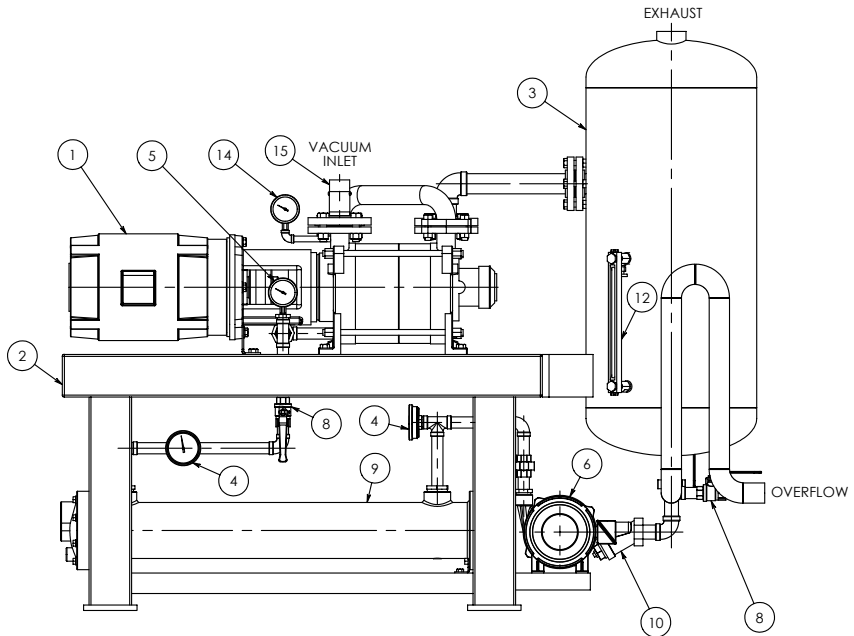
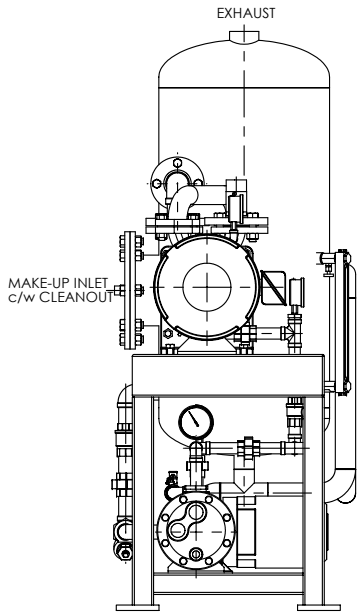
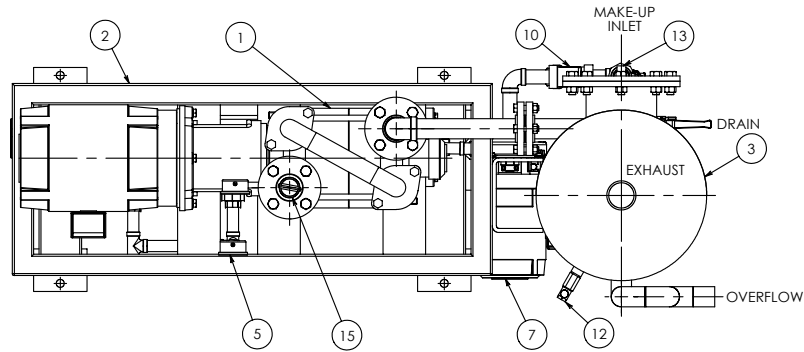

Premier Fluid Systems
Canadian Home of Travaini Pumps

4161 Morris Dr. - Unit 5 * Burlington * Ontario * L7L 5L5 * Website: www.pfspumps.com
Tel: 1-800-461-2611 or 905-637-2611 * Fax: 905-333-4722 * email: info@pfspumps.com

DATE : MARCH 2002

N°.: 2.13