

BARESHAF T CONSTRUCTION

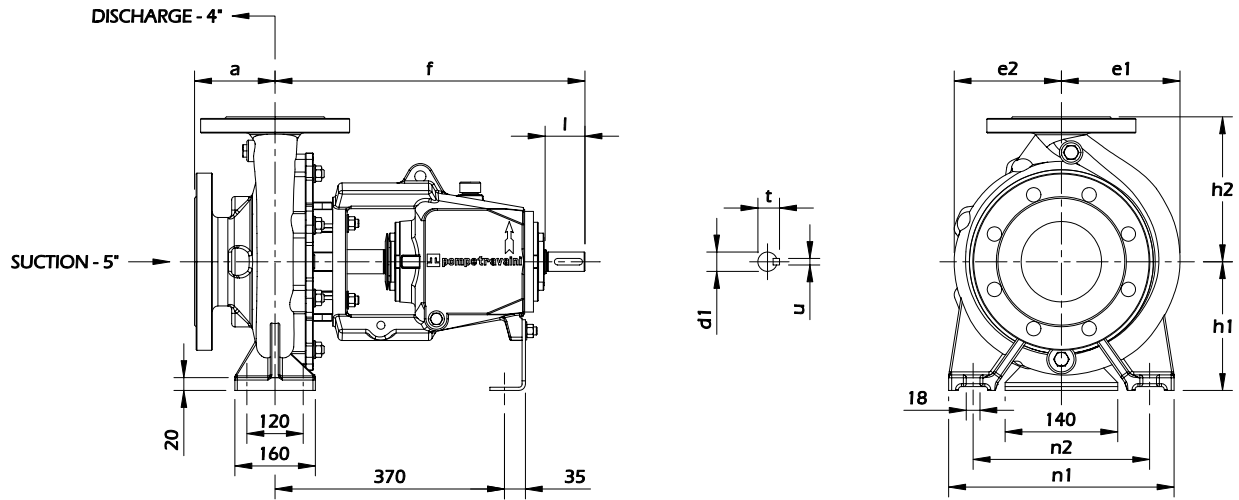

MODEL	a	f	h1	h2	n1	n2	d1	l	t	u	e1	e2	WEIGHT (Kg)
TCH 100-200	125	500	200	280	360	280	32	80	35	10	211	170	99
TCH 100-250	140	230	225		400	315	42	110	45	12	215	183	135
TCH 100-315			250	315	400	315	42	110	45	12	250	225	157

BASE-MOUNTED CONSTRUCTION

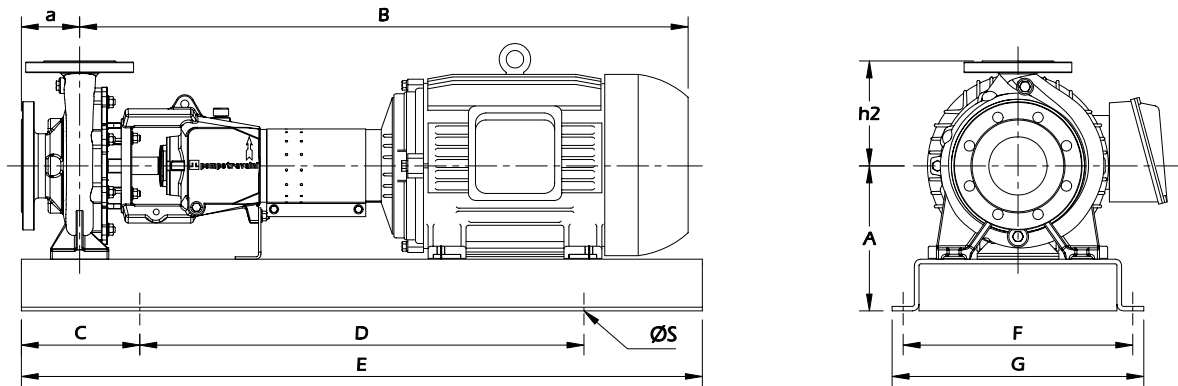

MODEL	MOTOR	HP*	A	B	C	D	E	F	G	S	BASE	WEIGHT (Kg)	
TCH 100-200	215T	10	302	1018	152	889	1194	470	508	16	907	243	
	254T	15		1115								276	
	256T	20	337	1162	229							1346	483
	365TS	75	365	1339	305	1041	1651	686	737		19	40F	634
	405TS	100	391	1432									740
	444TS	125	416	1558									910
	445TS	150		1564									1045

* Additional sizes available, contact Premier Fluid Systems Inc.

Dimensions in mm



Premier Fluid Systems
Canadian Home of Travaini Pumps

4161 Morris Dr. - Unit 5 * Burlington * Ontario * L7L 5L5 * Website: www.pfspumps.com
Tel: 1-800-461-2611 or 905-637-2611 * Fax: 905-333-4722 * email: info@pfspumps.com

DATE : DECEMBER 2006

No.: 15.125