

## Bareshaft Construction

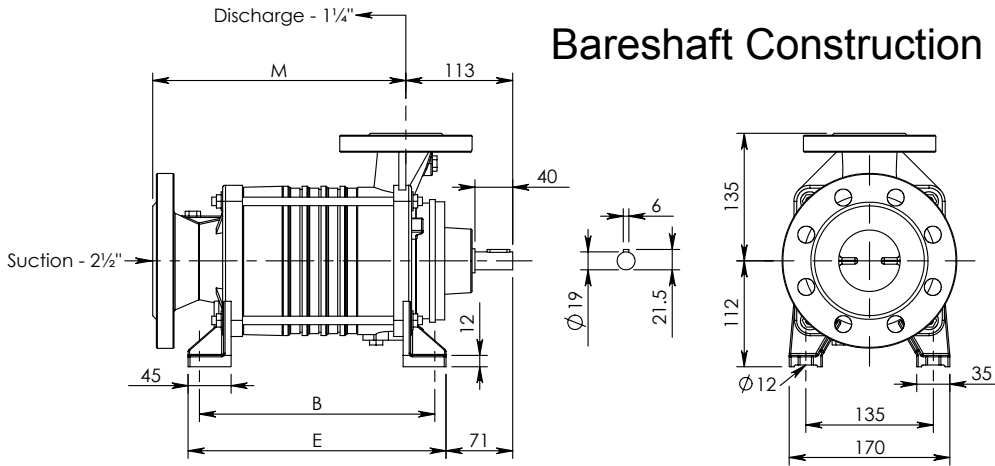

Model	M	B	E	Weight Kg
TBA 311	228	209	233	24
TBA 312	268	249	273	27.5
TBA 313	308	289	313	31
TBA 314	348	329	353	34.5
TBA 315	388	369	393	38
TBA 316	428	433	41.5	

## Base-Mounted Construction

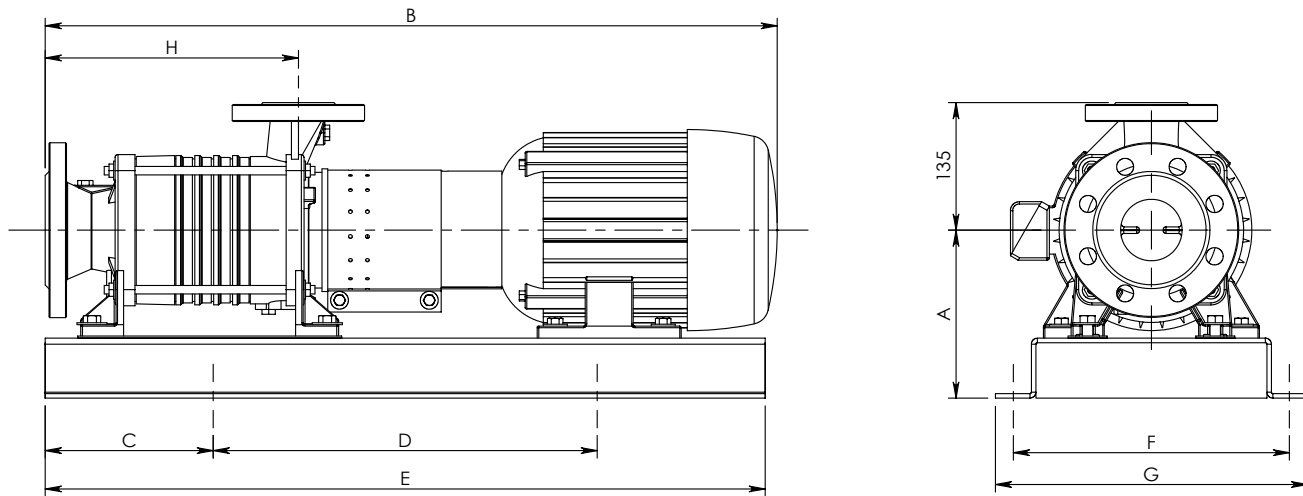

Pump Model	Motor HP	A	B	C	D	E	F	G	H	Base Plate	Weight (Kg.)
TBA 311	1 1/2	164	667	127	356	610	241	280	228	902	64
	2		692								68
	3	733	86								
TBA 312	3	178	775	178	406	762	292	330	268	901	91
	5		800								100
	7 1/2	864	136								
TBA 313	3	178	813	178	406	762	292	330	308	901	95
	5		838								104
	7 1/2	902	141								
TBA 314	5	178	883	178	610	965	318	356	348	900	113
	7 1/2		946								141
	10	991	150								
TBA 315	5	178	921	178	610	965	318	356	388	900	118
	7 1/2		984								145
	10	1029	154								
TBA 316	15	248	1092	203	762	1168	394	432	903	186	
	7 1/2	197	1022	178	610	965	318	356	428	900	150
	10		1067								159
15	248	1130	203								762

Flanges are R.F. drilled for 300 lbs ANSI mating flanges

Dimensions in mm



**Premier Fluid Systems**  
Canadian Home of Travaini Pumps

4161 Morris Dr. - Unit 5 \* Burlington \* Ontario \* L7L 5L5 \* Website: [www.pfspumps.com](http://www.pfspumps.com)  
Tel: 1-800-461-2611 or 905-637-2611 \* Fax: 905-333-4722 \* email: [info@pfspumps.com](mailto:info@pfspumps.com)

DATE : MARCH 2002

N°.: 13.9